

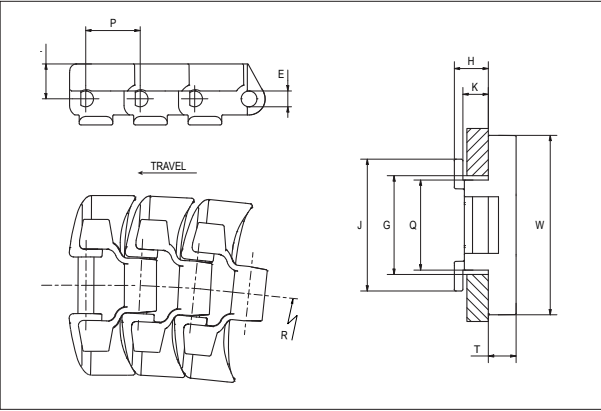

Slat Top Plastic Chain

Series **uni 255 FT** Type **TAB**

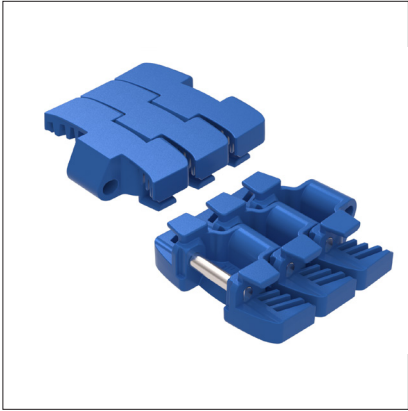

Slat Top Plastic Chain
 Side flexing chain
 Pitch: 25.4 mm (1.00 in)
 Backflex radius:
 200 mm (7.87 in)
 Permissible tensile strength:
 All POM materials: 1800 N (405 lbf)
 Standard shipping lengths:
 boxes of 120 links
 = 3.048 m (10.0 ft)

STANDARD

E		G		H		J		K		L		P		Q		T	
mm	in	mm	in	mm	in	mm	in	mm	in	mm	in	mm	in	mm	in	mm	in
7.1	0.28	44.5	1.75	15.7	0.62	61.5	2.42	11.7	0.46	16.2	0.64	25.4	1.00	42.0	1.65	12.7	0.50

All dimensions are for chains in POM material.

	Width (W)		Material & color	Pin material	Weight		Min. radius (R)	
	mm	in			kg/m	lb/ft	mm	in
K330	83.8	3.30	POM-D B G POM-DK DG PA6.6-GFH K	SS431	1.51	1.01	500	19.69
K450	114.3	4.50	POM-D B G PA6.6-GFH K	SS431	1.76	1.18	500	19.69

Non standard material and color: See uni Material and Color Overview.
 Non standard pin material: See uni Material and Color Overview.

SIDE FLEXING

PITCH 25.4 MM/1.00 IN



Sprocket

No. of teeth	Metric bore			Imperial bore		Overall diameter		Pitch diameter		Hub diameter		Dimension A		Dimension B		Machined solid sprocket PA6	Machined solid idler PA6		
	in	0.32	0.98	1.18	1.57													1.00	1.50
	mm	Pilot-Bore	25.0	30.0	40.0	25.4	38.1	mm	in	mm	in	mm	in	mm	in				
Z16								132.1	5.20	130.2	5.13	110.0	4.33	67.5	2.66	81.9	3.22		
Z18								148.5	5.85	146.3	5.76	126.0	4.96	75.7	2.98	89.9	3.54		
Z21								179.9	7.08	170.4	6.71	150.0	5.91	88.0	3.46	101.9	4.01		
Z31								254.2	10.01	251.1	9.89	230.0	9.06	128.6	5.06	142.1	5.59		

Machined solid sprocket Machined square bore

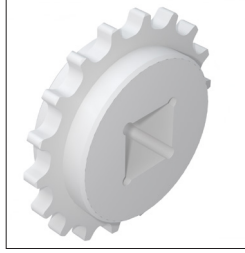
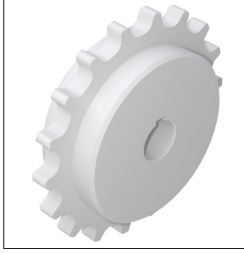

Non standard material and color:
See uni Material and Color Overview.
Width of tooth: 11.0 mm (0.43 in)
Width of sprocket: 30.0 mm (1.18 in)

Two-part sprocket

No. of teeth	Metric bore			Overall diameter		Pitch diameter		Hub diameter		Dimension A		Dimension B		Machined split sprocket PA6	Machined split idler PA6		
	in	0.32	0.98	1.18	1.57	mm	in	mm	in	mm	in	mm	in				
	mm	Pilot-Bore	25.0	40.0	mm	in	mm	in	mm	in	mm	in	mm			in	
Z16						132.1	5.20	130.2	5.13	110.0	4.33	67.5	2.66	81.9	3.22		
Z18						148.5	5.85	146.3	5.76	126.0	4.96	75.7	2.98	89.9	3.54		
Z21						179.9	7.08	170.4	6.71	150.0	5.91	88.0	3.46	101.9	4.01		
Z31						254.2	10.01	251.1	9.89	230.0	9.06	128.6	5.06	142.1	5.59		

Machined two-part sprocket

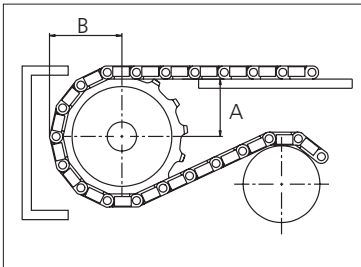

Please ensure that sufficient size shaft and keyway are chosen for corresponding load.

Non standard material and color:
See uni Material and Color Overview.

Other sprocket sizes are available upon request
Width of tooth: 11.0 mm (0.43 in)
Width of sprocket: 30.0 mm (1.18)
uni Retainer Rings: See uni Retainer Ring data sheet
uni Idler: See uni Idler data sheet

uni 255 TAB/2024_06.28 --



The local partner of choice for sustainable conveyor belting solutions – around the globe.
<http://eptool.online>

Member of Ammega Group.



Scan the QR code and find your local contact

Ammeraal Beltech Modular
Hjulmagervej 21
DK-7100 Vejle
T +45 7572 3100

<http://eptool.online>

This information is subject to alteration due to continuous development. Ammeraal Beltech will not be held liable for the incorrect use of the above stated information. This information replaces previous information. All activities performed and services rendered by Ammeraal Beltech are subject to general terms and conditions of sale and delivery, as applied by its operating companies.